

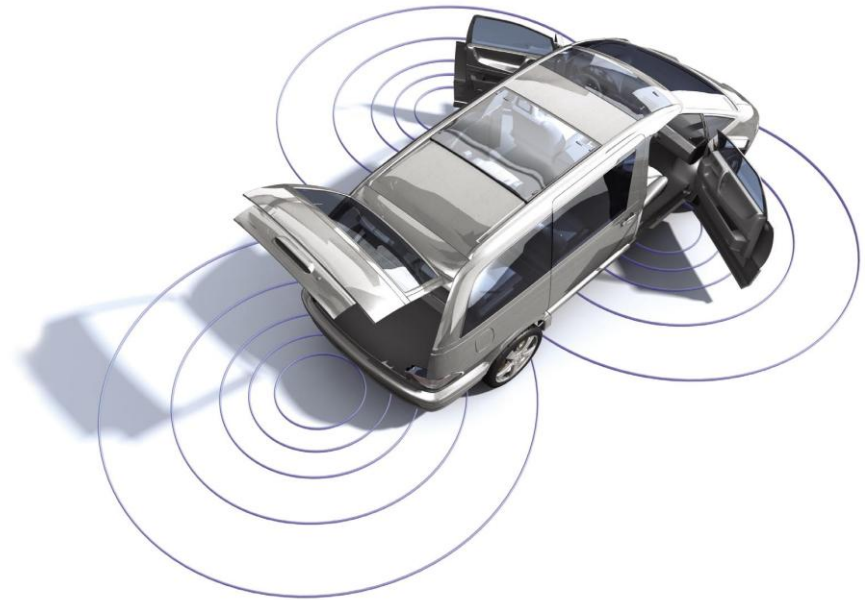

NXP Semiconductors Enabling Connected Mobility

September 2011



Contents

- ▶ Connected Mobility – What Is Driving This Trend
- ▶ NXP positioning in Connected Mobility
- ▶ Introduction into Intelligent Transportation Systems (ITS)
- ▶ ATOP Telematics solution for mass market
- ▶ Introduction IEEE802.11p based communication for V2X
- ▶ V2X communication challenges
- ▶ Intro MK3
- ▶ Transparent truck use case
- ▶ Field Trials Worldwide with NXP engagement
- ▶ Summary



Connected Mobility – What Is Driving This Trend

Riding on the success of Smart Phones

- ▶ People want to be always online / always connected
- ▶ Connectivity is improving rapidly (LTE, NFC)
- ▶ Apps are used for everything / users define the content
- ▶ Wish for more **convenience and road safety**
- ▶ De-motorization / car and ride sharing
 - Young people feel less attached to vehicles
 - Improved public transport and car/ride **sharing** to cope with traffic in mega cities
- ▶ For more visit <http://www.myconnectedcar.com>



NXP Driving Innovation & Growth in Automotive

Established
leadership positions

→ driving growth →

In-vehicle networking

CAN / LIN

- Transceivers
- System Basis Chips

NXP #1

Car access & immobilizers

- Immobilizers and Remote Keyless Entry

NXP #1

Car entertainment

- Radio/Audio DSP
- Tuner
- Audio Amplifiers

NXP #1

Magnetic Sensors

- Speed (ABS, engine)
- Angular (steering, throttle)

NXP #3

**Connected
Mobility**

ATOP
MK3



CO₂ reduction

... And What It Takes to Make It Real !

Enabling technologies to connect the car



Location-based services
(Telematics, NFC, Authentication)

Personalization
(NFC, Authentication)

Broadcast Reception
(Software-defined Radio, Digital Radio, AM/FM)

Remote Car Management
(Two-way RF, Telematics, Authentication)

Car-to-x Communication
(802.11p via Software-defined Radio, Telematics, Authentication)



Rationale of ITS:

Clear benefits for society

The Problem

Safety

- 32,788 highway deaths in 2010
- 6,000,000 crashes/year
- Leading cause of death for ages 4 to 34

Mobility

- 4,200,000,000 hours of travel delay
- \$80,000,000,000 cost of urban congestion

Environment

- 2,900,000,000 gallons of wasted fuel

Courtesy Shelley Row
ITS Joint Program Office,
USDOT

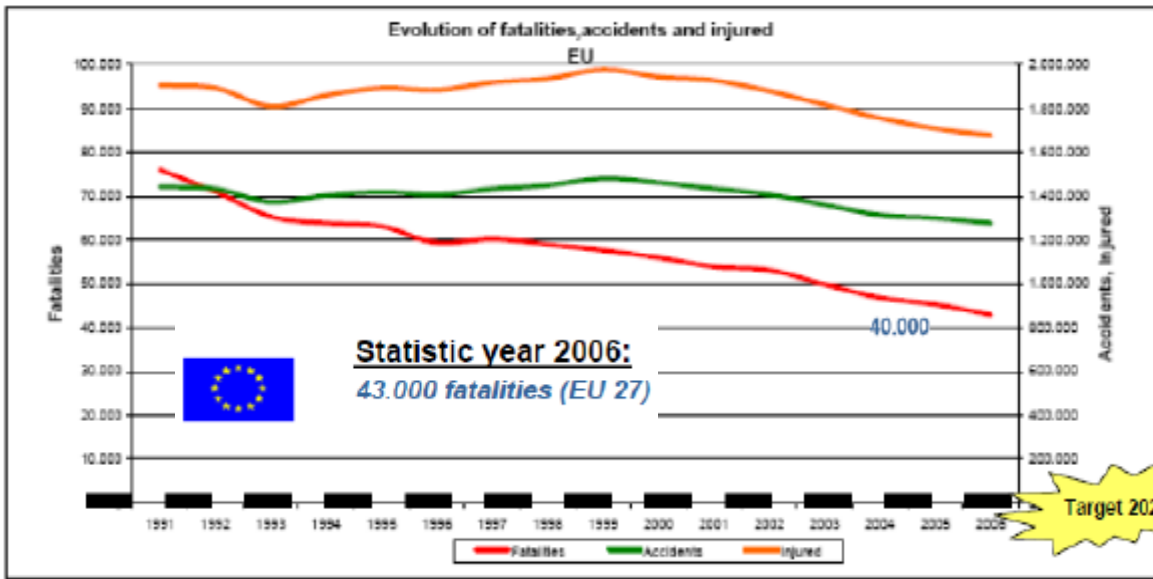
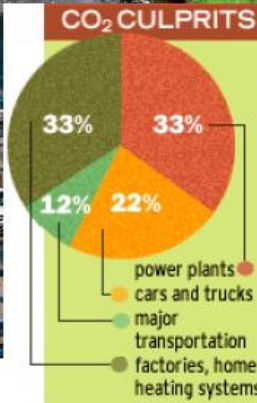

Source : CARE (EU road accidents database) or national publications
European Commission / Directorate General Energy and Transport

Clear society benefits ITS:

- 50% less traffic fatalities
- 50% less traffic jams
- 10% less CO2 emissions
- 6B€ GNP improvement NL*

* TNO report 2010

ITS - V2X

Range & Latency are key for safety

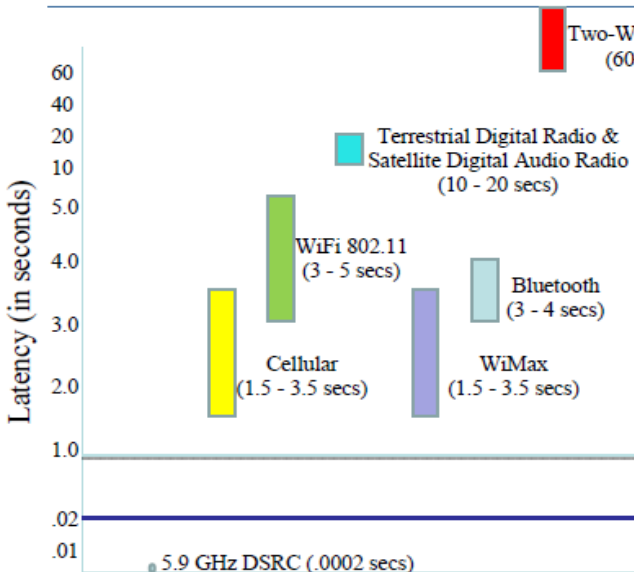
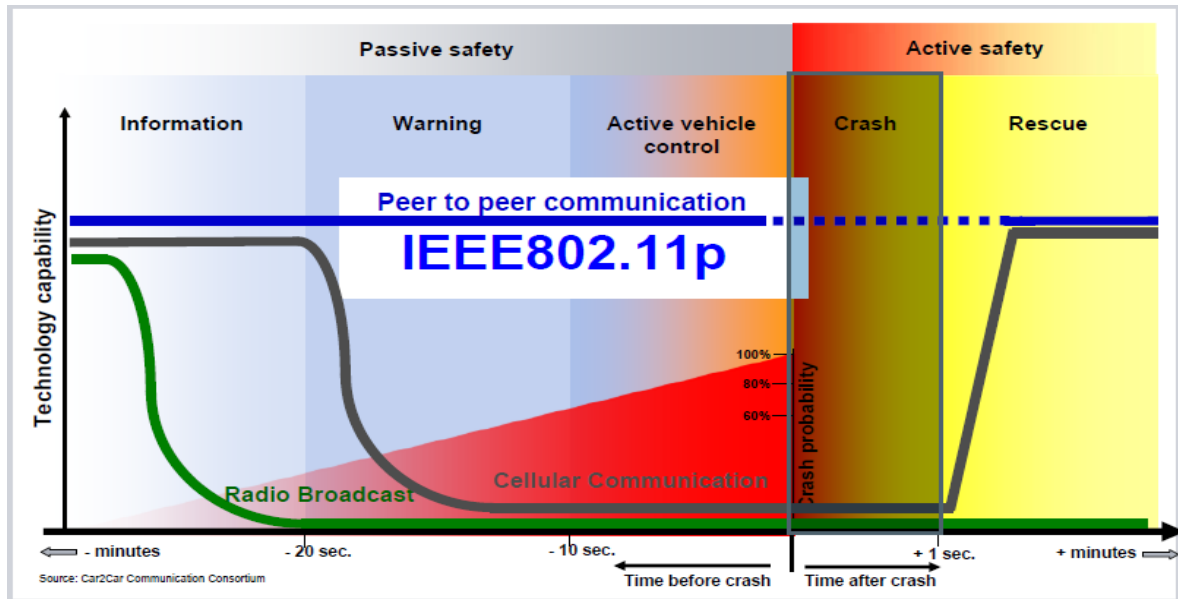

Active Safety Latency Requirements (secs)	
Traffic Signal Violation Warning	0.1
Curve Speed Warning	1.0
Emergency Electronic Brake Lights	0.1
Pre-Crash Sensing	0.02
Cooperative Forward Collision Warning	0.1
Left Turn Assistant	0.1
Lane Change Warning	0.1
Stop Sign Movement Assistance	0.1

Least stringent latency requirement for Active Safety (1 sec)

Most Stringent latency requirement for Active Safety (.02 sec)

- ▶ **Passive Safety:**
 - Being informed (broadcast)
No need for immediate action
 - Being Warned (E-call)
Be aware something happened
- ▶ **Active Safety**
 - Being warned / controlled (V2X DSRC)
Need to ASAP take action
- ▶ **Only IEEE802.11p can fulfill latency requirements**

Note: Y-axis not to scale for illustration purposes

Data source: Vehicle Safety Communications Project – Final Report

ITS Connected Mobility: Safety & Convenience

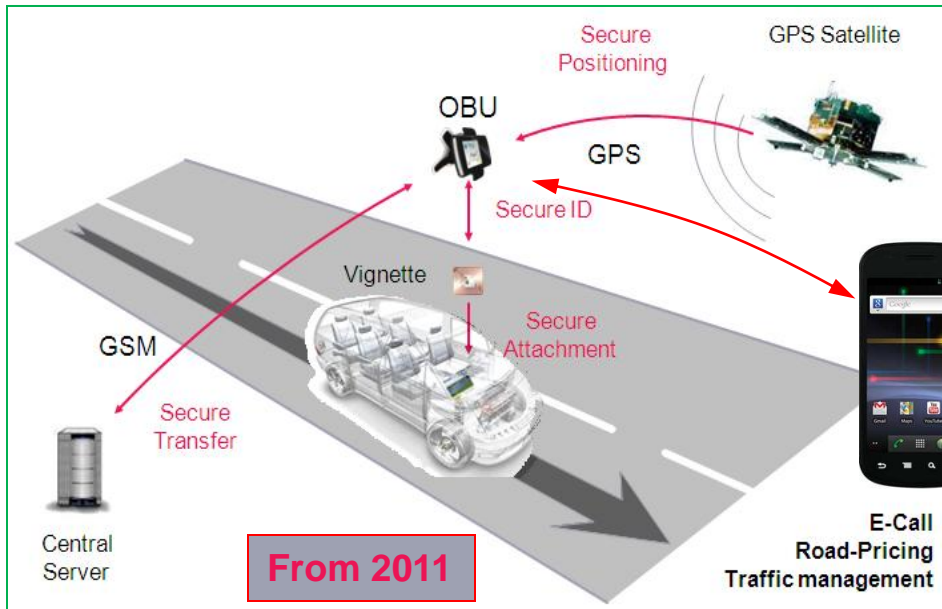

Convenience, Security & Online services

ATOP

- eCall, Stolen Car Tracking
- Remote Smart phone management
- Remote Diagnostic
- Pay As You Drive
- Fleet Management/Car share
- E-Car - Car Charging

MK3

Safety & Efficiency

- Hazardous Location Notification
- Forward Collision Warning
- Pre-Crash Sensing
- Curve speed warning
- Lane change warning
- Green Light optimal speed Advisory

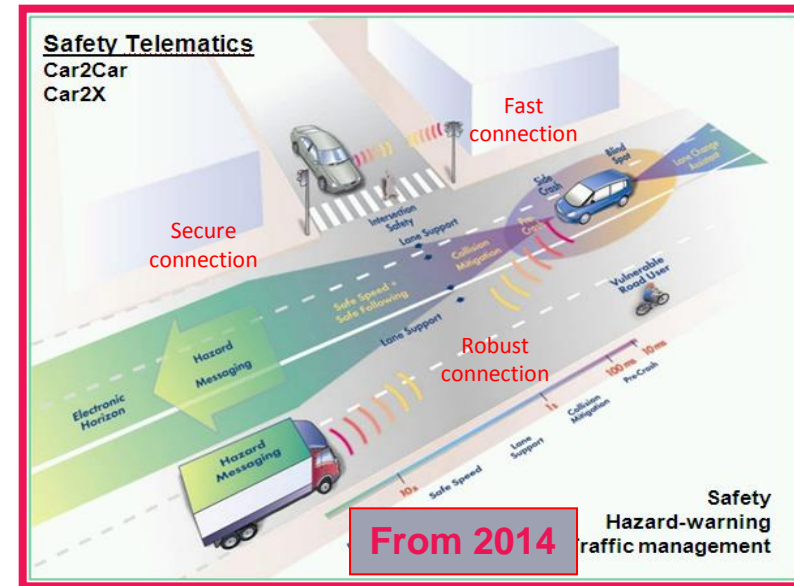

ATOP Telematics solution for mass market

- ▶ **Easy programmability** to reduce time-to-market, enable better user action and added services
- ▶ Ability to integrate **multiple services in one unit** (e.g. eCall, stolen vehicle tracking, remote diagnostics)
- ▶ **Security** to safeguard privacy, protect content and prevent manipulation (e.g. in road pricing)
- ▶ **Small form factor**
- ▶ **Low cost**
- ▶ **Automotive grade**

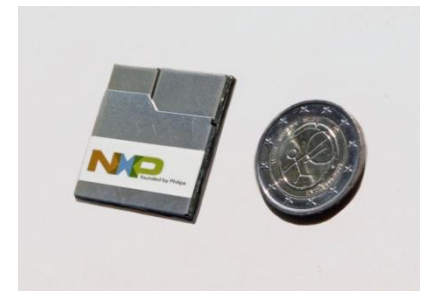
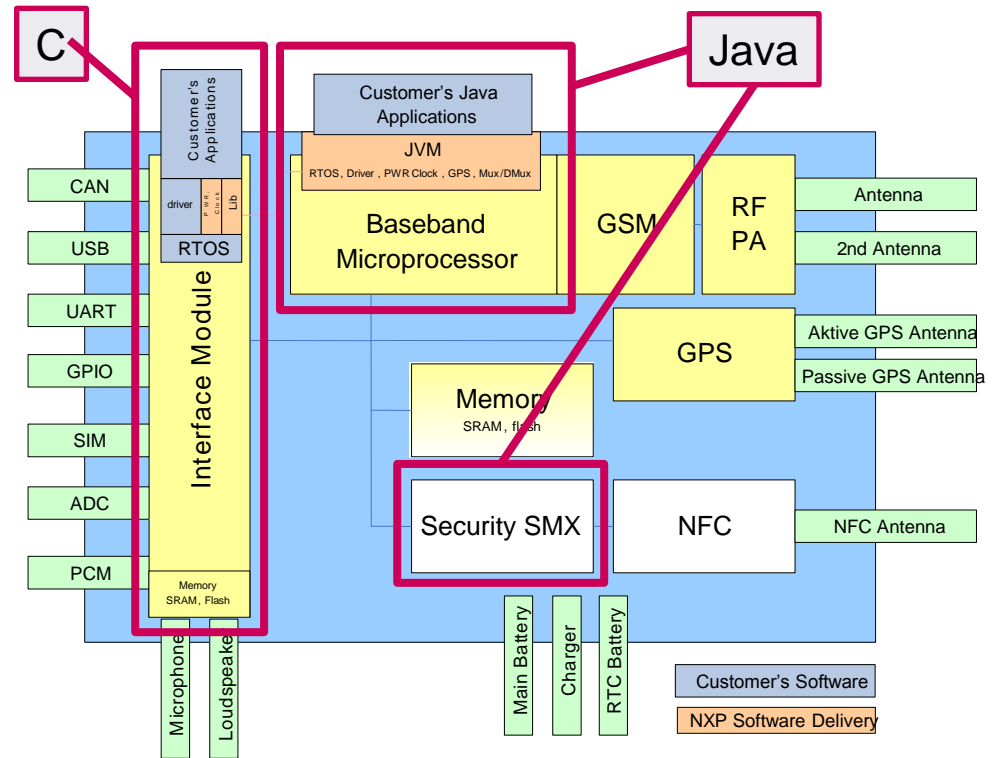

V2X – key challenges

Not met by standard off the shelf WIFI technology

- ▶ Ability to „see“ through objects
- ▶ Reliable reception quality even in high-rise building surroundings
- ▶ Good reception in fast-moving compared to static objects
- ▶ Cost-efficiency to enable mass deployment
- ▶ Flexibility to cover all communication standards
- ▶ Low power-consumption

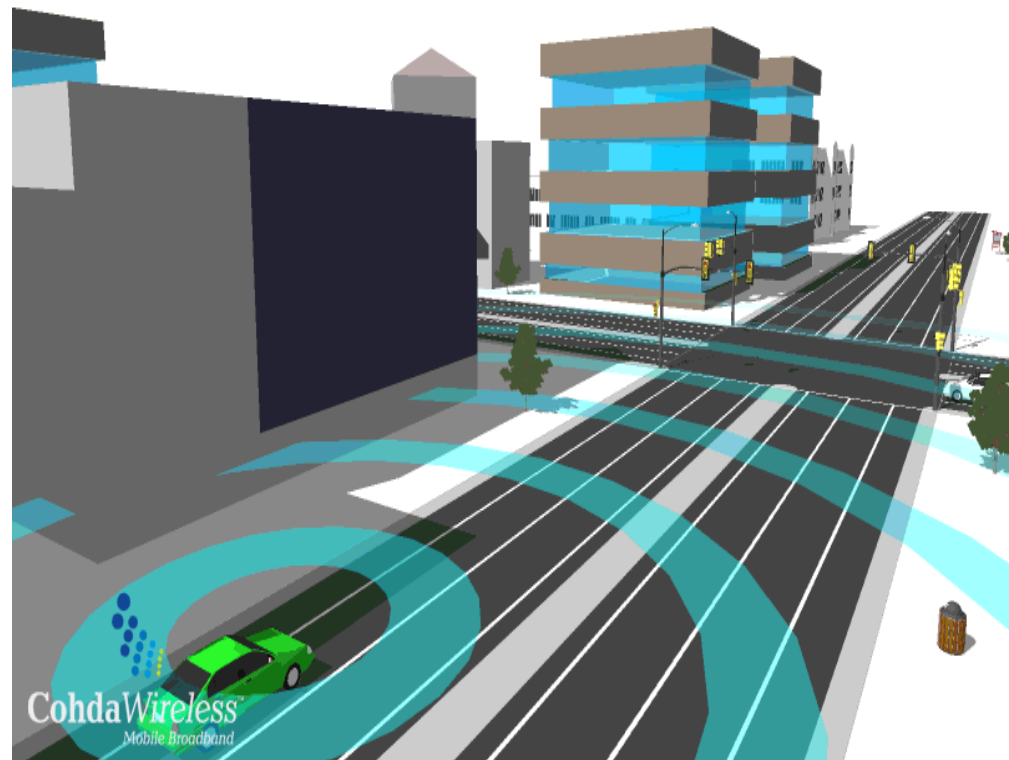

DSRC for ITS (V2X)

Introduction of IEEE802.11p

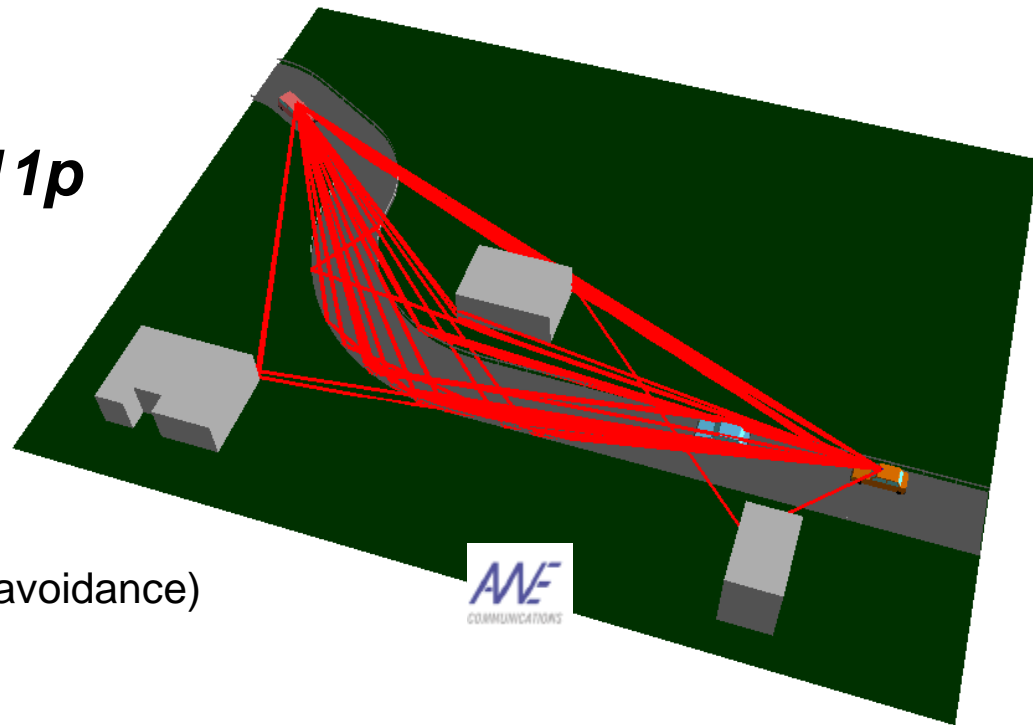

- ▶ **IEEE802.11p** WIFI based:
 - 802.11a: PHY (BW \leq 10MHz)
 - 802.11e: message prioritisation
 - 802.11 MAC: CSMA/CA (collision avoidance)

- ▶ Changes to WIFI 802.11 required
 - **Longer ranges** (up to 1000m)
 - **High (relative) speed of vehicles** (Doppler)
 - **Low latency** by
 - No frequency scanning
 - No authentication and Association
 - **Robust** under automotive harsh conditions
 - Rapid changes in multi-paths reflections
 - Long excess delays to indoor

	Suburban	Highway	Rural
Max Excess Delay τ_m (15 dB)	0.6 μ s	1.4 μ s	1.5 μ s

	5 MHz	10 MHz (p)	20 MHz (a)
OFDM Guard Interval T_{GI}	3.2 μ s	1.6 μ s	0.8 μ s

- ▶ Room for differentiation in the PHY for higher link budget: **Better see through object**¹

NXP Flexible Multi-Standard V2X Platform

Covering the V2X standards for EU, US and Japan.

Cohda Wireless **advanced Radio** to increase link robustness

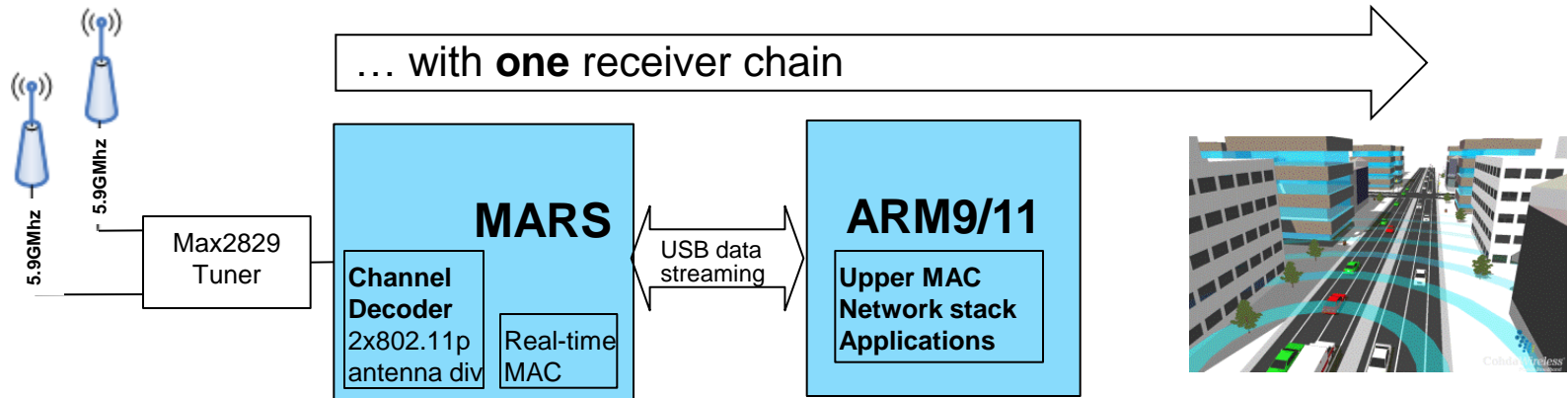

Overview Requested ITS standards EU/US

- ✓ Single / Dual Channel 802.11p
- ✓ Single / Dual Channel 802.11p, 2-antenna diversity

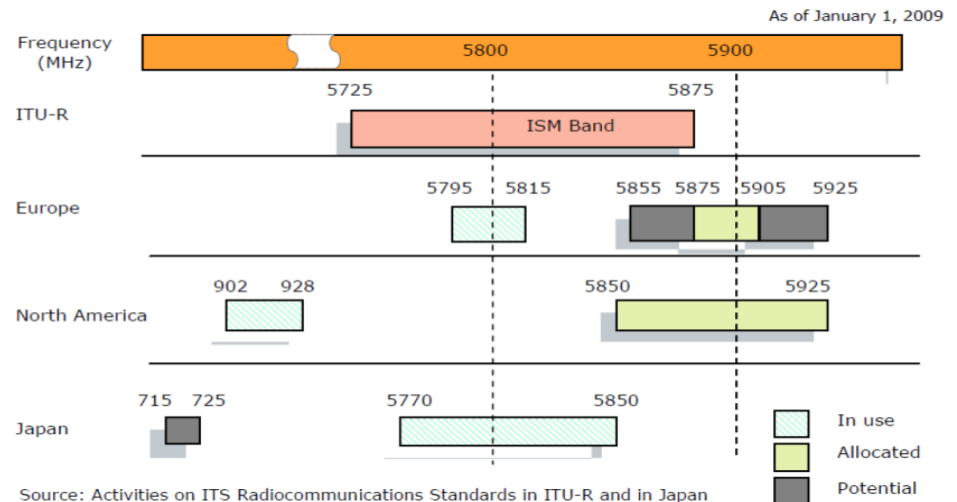

Japan

- ✓ V2V single channel, 720 or 760MHz
- ✓ V2I single channel, 5.8GHz
- ✓ V2V single channel and V2I single channel
- ✓ Diversity WAVE, single channel

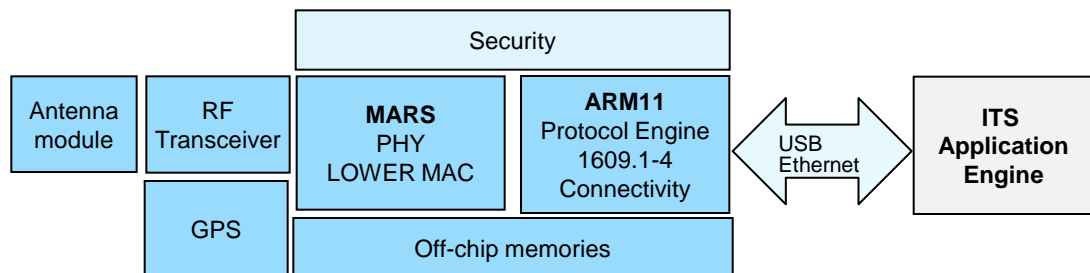

MK3 platform for V2X

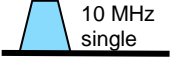

IEEE 802.11p Use case	MK3
 10 MHz single	
 10 MHz single diversity	
 10 MHz dual	

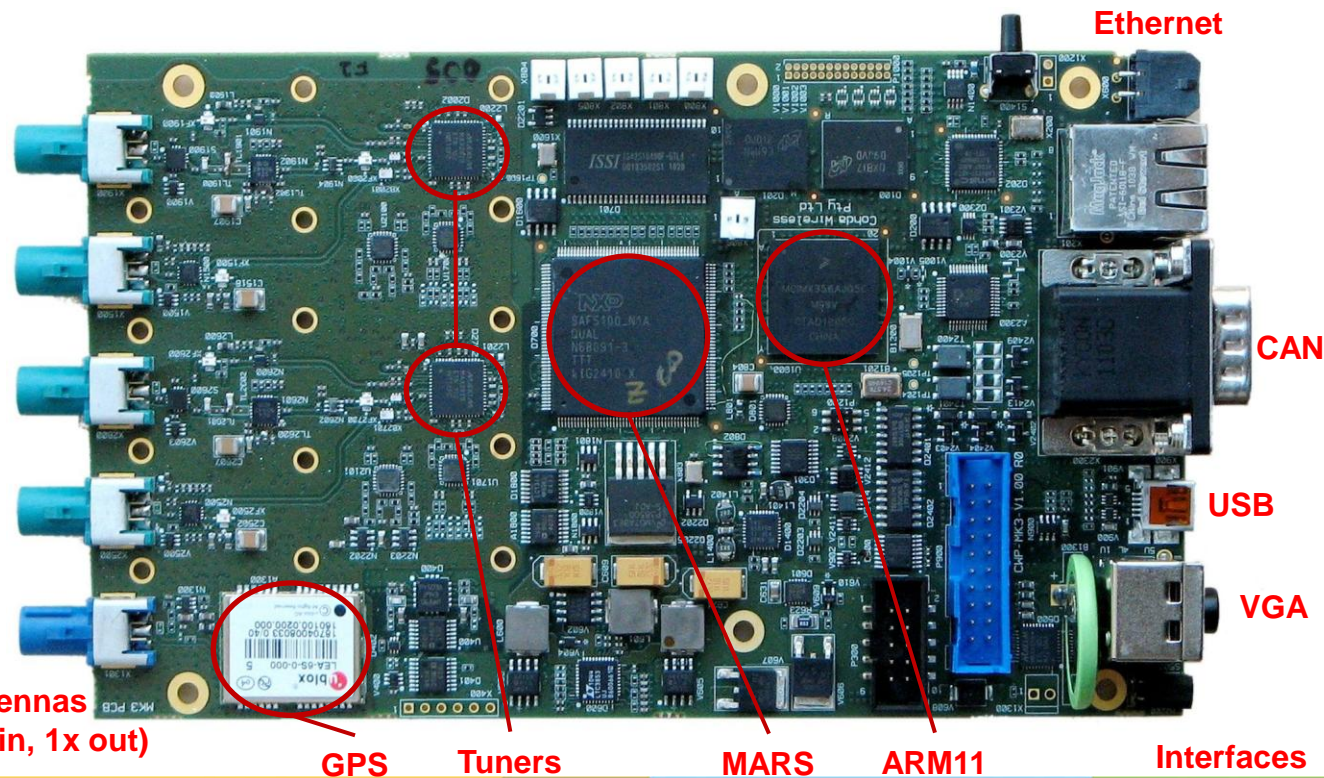

- ▶ Linux based ARM11 for easy integration
 - ETSI based upon IEEE1609.4
 - CALM Fast
- ▶ Command line based interface on host to control MK3
- ▶ Complete IEEE1609 stack available

Automotive Week / SPITS event Eindhoven

Home Car-to-car communications Car-to-infrastructure communications Location based services

Car-to-car communications

Imagine the possibilities if instead of the car simply being a passive receiver of information, it was actually an active information source. With IEEE 802.11p technology, the dedicated Wi-Fi standard supporting Intelligent Transportation Systems (ITS) applications, that is exactly what is possible. With key information being passed seamlessly between vehicles over 802.11p safely on roads can be dramatically improved through features such as forward hazard warning. NXP has co-developed an IEEE 802.11p-based car-to-X (C2X) platform with Australian-based *Coda Wireless*.

NXP's enabling technologies

- IEEE 802.11p
- Authentication

Application examples

- Forward hazard warning
- curve speed warning
- overtake vehicle warning
- Collision warning
- emergency brake light
- Blue light emergency vehicle warning

Demos / Trials

During Automotive Week 2011 in Helmond, the Netherlands, NXP together with our SPITS partners will be showcasing this technology on the road. [Check out On the road with SPITS](#) for more information.



Results MK3 Field-testing

- MK3 shows superior reception performance

- ▶ Comparison done against other C2X 802.11p solutions
 - Based on consumer-grade WiFi chips (COTS)
 - SPITS demo - Transparent truck use-case where drivers cannot see each other past large vehicles
- ▶ MK3 is superior to COTS in this and many other safety-beneficial C2X use-case scenarios:

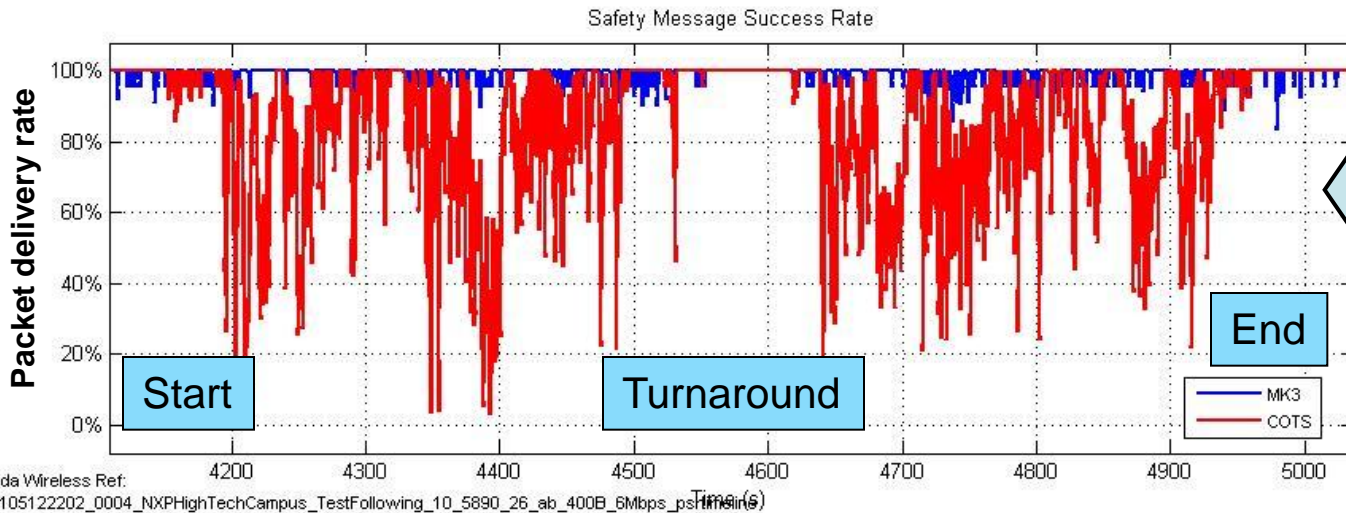

- 90 km/h highway
- Highway spacing
- MK3 good
- Many COTS failures
- COTS OK when stopped at start, end, and turnaround

Field Trials Worldwide with NXP engagement



U.S. Department of Transportation
Federal Highway Administration



USDOT ASD
Establishes a real world model deployment site (vehicle communications environment)
Partners
Delphi, Cohda Wireless

simTD
Shaping tomorrow's mobility through researching and testing car-to-x and its applications
Partners
Continental, Daimler, Audi, BMW, Opel, VW, Cohda Wireless

Korea
Targeted car2carfield trial
Partners
Mobis, Hyundai, Cohda Wireless

Japan
Targeted car2carfield trial
Partners
Denso, Cohda Wireless

Score@F
Regional Field trial in Paris region to apply car2x technology
Partners
Renault, PSA, Cohda Wireless

Austria
Targeted car2carfield trial
Partners
TomTom, Cohda Wireless

ConnectSafe
Australia's first field trial and on-road demonstration of dedicated short range communications
Partners
University South Australia, Cohda Wireless



PSA PEUGEOT CITROËN

SCORE@F



Summary

- ▶ Society benefits for ITS (Passive and Active Safety) are clear.
- ▶ Active safety is based upon IEEE802.11p communication to replace / as addition to sensor information.
- ▶ There is room for differentiation by providing better link quality for active safety to better deal with harsh automotive conditions.
- ▶ NXP has demonstrated the MK3 platform for V2X, featuring Cohda's Advanced Radio for superior reception quality compared to COTS WLAN solutions.
- ▶ MK3 is a flexible platform, featuring SDR technology, capable to support worldwide V2X communication standards.
- ▶ Engagement of NXP in many worldwide Field Trials.

NXP

